

INDUSTRIAL TEMPERATURE SENSOR



THERMOCOUPLE RESISTANCE THERMOMETER

These sensors are intended for temperature measurements at industrial job sites, and are available in two types, thermocouples and resistance thermometers.

Each sensor consists of a connection head, a protective tube, mounting fixture, an element, and an insulation tube. Depending on kinds of the protective tube and the mounting fixture, they are divided into straight types, flange types, nipple types, and L types.

■ FEATURES

- By selecting a proper sensor, measurements over a broad temperature range from -200°C to 1600°C are possible.
- By selecting a proper protective tube made of metal or non-metallic material, temperature measurements in corrosive atmosphere are possible.
- Elements made of carefully selected materials with good craftsmanship permit highly accurate temperature measurements.



MODELS

(Example) Type K (Ø1.0mm) with a fixed nipple and a stepped tube.

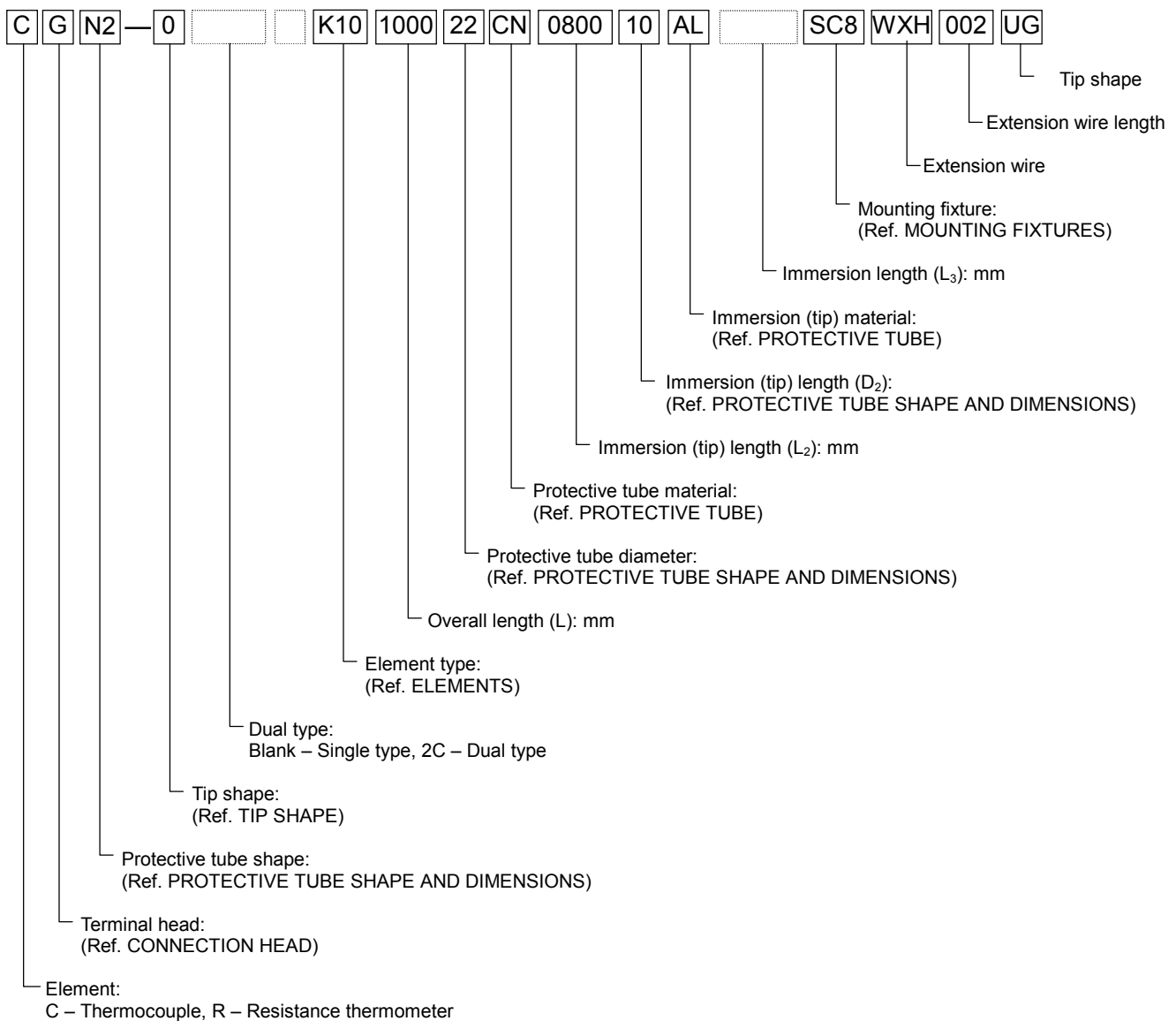
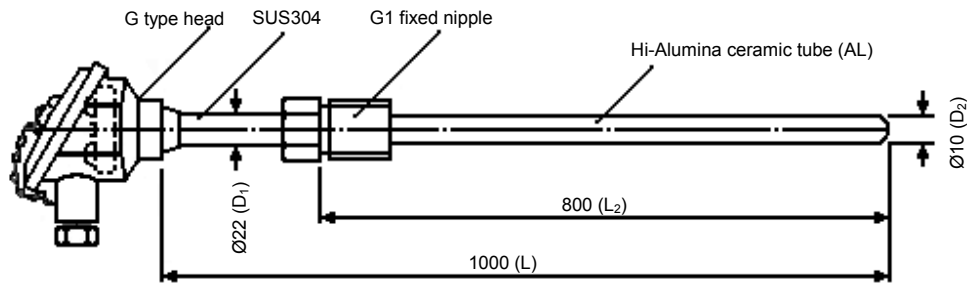

PROTECTIVE TUBE SHAPE AND DIMENSIONS

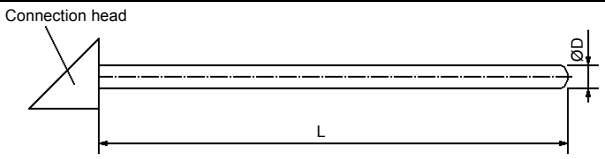
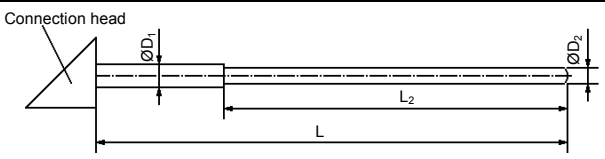
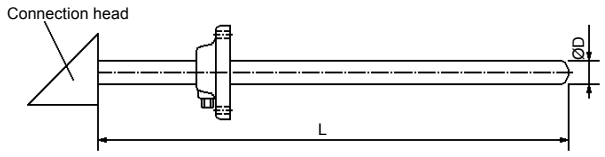
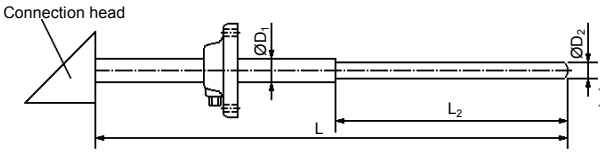
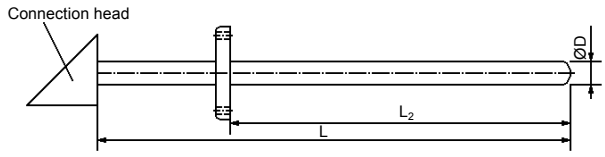
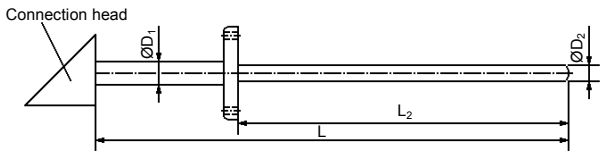
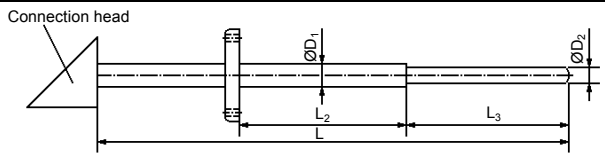
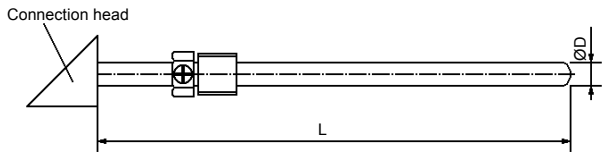
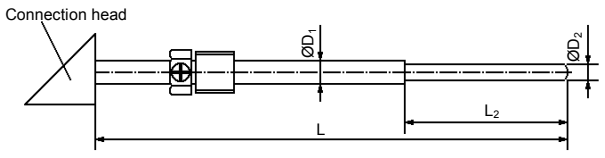
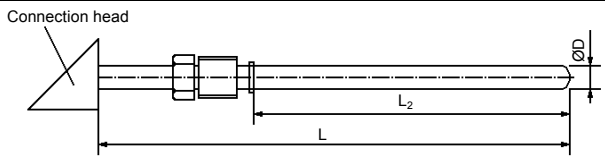
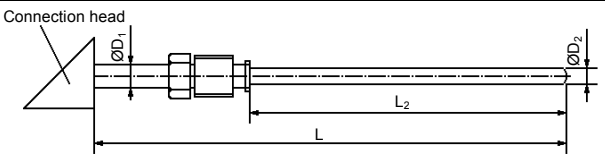
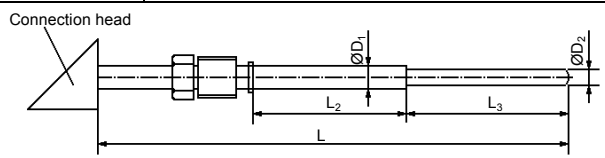
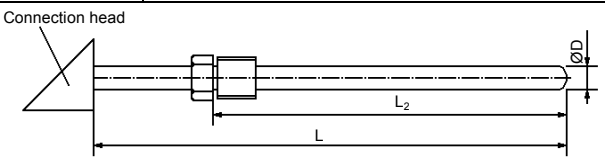
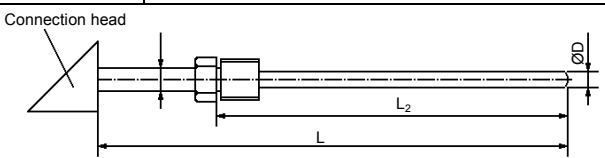
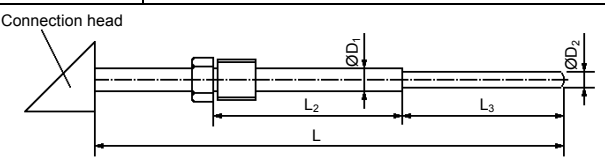
Straight type	
Code: S1 Straight type	Code: S5 With stepped tube
	
With flange	
Code: S2 With sliding flange	Code: S6 With sliding flange (stepped tube)
	
Code: F1 With fixed flange	Code: F2 With fixed flange (stepped tube)
	
Code: F3 With fixed flange (stepped tube)	
	
With nipple	
Code: S3 With screw fixing nipple	Code: S7 With screw fixing nipple (stepped tube)
	
Code: N4 With sliding nipple	Code: N5 With sliding nipple (stepped tube)
	
Code: N6 With sliding nipple (stepped tube)	Code: N1 With fixed nipple
	
Code: N2 With fixed nipple (stepped tube)	Code: N3 With fixed nipple (stepped tube)
	

L type

Code: L1 | L type

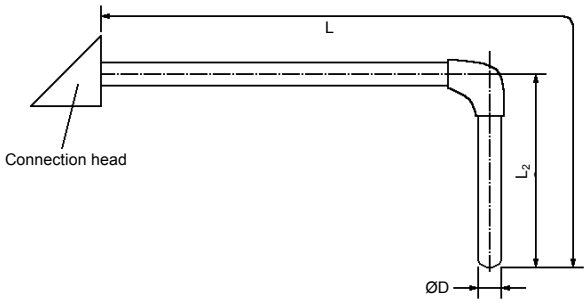

Code: L2 | L type (with flange)

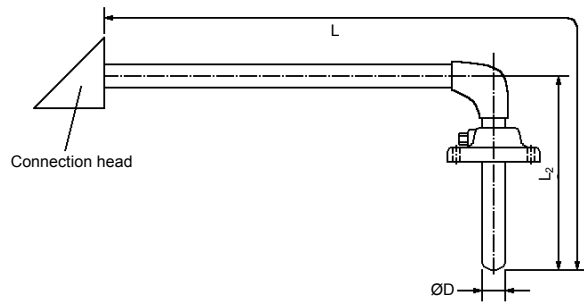

Code: L3 | L type (with flange)

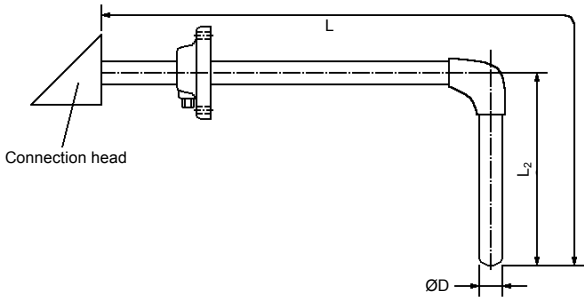

Code: L4 | L type (with nipple)

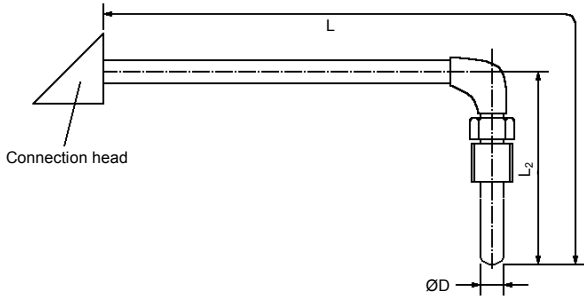

Code: L5 | L type (with screw fixing nipple)

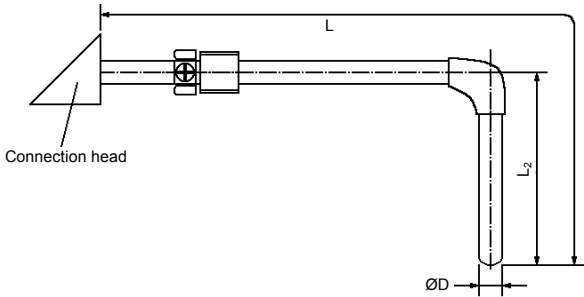

Dual protective tube type

Code: D1 | Straight type

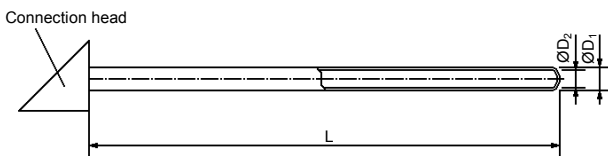

Code: D2 | With sliding flange

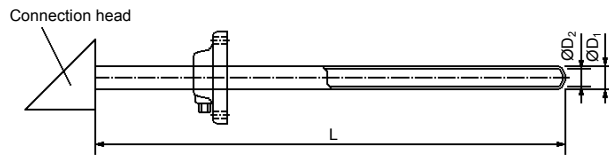

Code: D3 | With screw fixing nipple

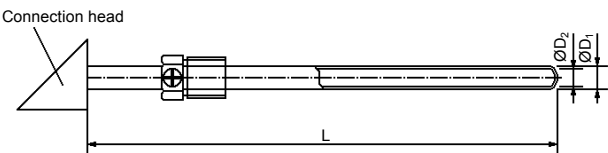



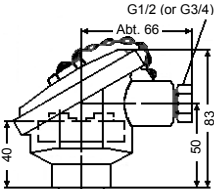
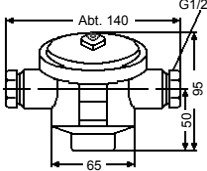
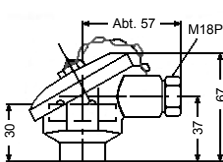
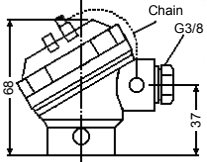

Dual protective tube type	
Code: D4 L type	Code: D5 With fixed nipple
Code: D6 L type (with sliding flange)	Code: D7 L type (with screw fixing nipple)
Code: D8 L type (with screw fixing nipple)	
Dual protective tube type with fixed accessory	
Code: W1 Straight type	Code: W2 With sliding flange (stepped tube)
Code: W3 With fixed nipple (stepped tube)	Code: W4 With fixed flange
Code: W5 With fixed flange (stepped tube)	Code: W6 With fixed flange (stepped tube)

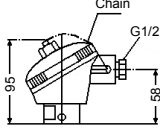
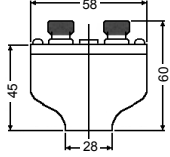
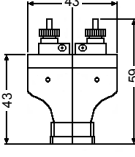
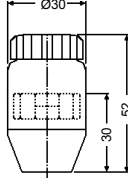
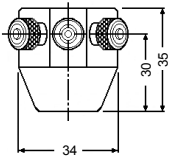
■ CONNECTION HEAD

Code		G	W	S	E
External dimensions					
Material		Cast aluminum	Cast aluminum	Cast aluminum	Phenol resin
Construction		Closed waterproof	Closed waterproof	Closed waterproof	Closed waterproof
Protective tube diameter (mm)	Metallic	Ø15, Ø22, Ø27	Ø6, Ø8, Ø10, Ø12, Ø15, Ø22, Ø27	Ø3.2, Ø4.8, Ø6, Ø8, Ø10, Ø12	Ø6, Ø8, Ø10, Ø12
	Non-metallic	Ø15, Ø17, Ø21	Ø6, Ø8, Ø10, Ø15, Ø17, Ø21	Ø6, Ø8	

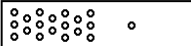
Code		F	B	T	P	M
External dimensions						
Material		Phenol resin	Cast aluminum	Cast aluminum	Cast aluminum	Phenol resin
Construction		Closed waterproof	Terminal exposure	Terminal exposure	Closed waterproof	Terminal exposure
Protective tube diameter (mm)	Metallic	Ø15, Ø22	Ø15, Ø22	Ø3.2, Ø4.8, Ø6, Ø8, Ø10, Ø12	Ø3.2, Ø4.8, Ø6, Ø8, Ø10, Ø12	Ø3.2, Ø4.8, Ø6, Ø8, Ø10, Ø12
	Non-metallic		Ø10, Ø15, Ø17, Ø21	Ø6, Ø8	Ø6, Ø8	Ø6, Ø8

■ TIP SHAPE

Code	Shape	Code	Shape
0	Closed type 	4	Net type 
2	Open type 	5	Ground type 
3	Exposed type 		

■ MOUNTING FIXTURES

● Flange

Fixed flange	Nominal size	Code		ØD	Flange dimension				Bolt hole			
		A	B		SUS304	SUS316	T	F	Øg	H	ØC	Øh
	Basic dimension of 5kg/cm ² flange											
	10	3/8	FC3	FM3	75	9	1	39	34	55	12	4
	15	1/2	FC4	FM4	80	9	1	44	34	60	12	4
	20	3/4	FC6	FM6	85	10	1	49	35	65	12	4
	25	1	FC8	FM8	95	10	1	59	35	75	12	4
	40	1-1/2	FCD	FMD	120	12	2	75	37	95	15	4
	50	2	FCE	FME	130	14	2	85	39	105	15	4
	65	2-1/2	FCF	FMF	155	14	2	110	39	130	15	4
	80	3	FCG	FMG	180	14	2	121	39	145	19	4
	Basic dimension of 10kg/cm ² flange											
	10	3/8	JC3	JM3	90	12	1	46	37	65	15	4
	15	1/2	JC4	JM4	95	12	1	51	37	70	15	4
	20	3/4	JC6	JM6	100	14	1	56	39	75	15	4
	25	1	JC8	JM8	125	14	1	67	39	90	19	4
	40	1-1/2	JCD	JMD	140	16	2	81	41	105	19	4
	50	2	JCE	JME	155	16	2	96	41	120	19	4
	65	2-1/2	JCF	JMF	175	18	2	116	43	140	19	4
	82	3	JCG	JMG	185	18	2	126	43	150	19	8
	100	4	JCH	JMH	210	18	2	151	43	175	19	8
	Basic dimension of 20kg/cm ² flange											
	25	1	KC8	KM8	125	16	1	67	41	90	19	4
	40	1-1/2	KCD	KMD	140	18	2	81	43	105	19	4
	50	2	KCE	KME	155	18	2	96	43	120	19	8
65	2-1/2	KCF	KMF	175	20	2	116	45	140	23	8	
80	3	KCG	KMG	200	22	2	132	47	160	23	8	
100	4	KCH	KMH	225	24	2	160	49	185	23	8	

Nominal size	Applicable protective tube diameter Ød	Code			Flange diameter ØD	Flange		Bolt hole			Mounting bolt
		Sliding flange	Fixed flange			t	h	Center hole diameter ØC	Number n	Diameter ØE	
			Aluminum	SUS304							
A	17 to 32	SAA	FCA	FMA	100	10	34	70	4	10	M8
B	8 to 16	SAB	FCB	FMB	70	7.5	28	50	4	8	M6
C	6.4 or less	SAC	FCC	FMC	50	3	13	35	4	4.5	M4

● Nipple

Nominal size (B)	Applicable protective tube diameter Ød	Code				Screw dimension		Thread number per inch	Opposite side and opposite angle distance		A	B	K
		Parallel screw		Tapered screw		Outside diameter C	Core diameter		G	F			
		SUS304	SUS316	SUS304	SUS316								
G, R1/8	6 or less	SC1	SM1	TC1	TM1	9.7	8.56	28	14	16.2	6	10	4.0
G, R1/4	22 or less	SC2	SM2	TC2	TM2	13.1	11.4	19	47	19.6	8	12	6.0
G, R3/8	22 or less	SC3	SM3	TC3	TM3	16.6	14.9	19	21	24.2	10	15	6.4
G, R1/2	22 or less	SC4	SM4	TC4	TM4	20.9	18.6	14	26	30	12	20	8.2
G, R3/4	16 or less	SC8	SM6	TC6	TM6	26.4	24.1	14	32	37	16	23	9.5
G, R1	22 or less	SC8	SM8	TC8	TM8	33.2	30.2	11	41	47.3	20	30	10.4

• **Compression fitting**

<p>Type 1</p>	Copper	CF1	CF2	CF3	CF4	CF6	CF8
	Teflon	CR1	CR2	CR3	CR4	CR5	CR6
	Screw	R1/8	R1/4	R3/8	R1/2	R3/4	R1
	For Ø1.0	A=35 B=10 G1=14 G2=14	A=31 B=12 G1=17 G2=14	A=36 B=15 G1=21 G2=14	A=43 B=20 G1=26 G2=14	A=50 B=18 G1=32 G2=14 G3=17	A=52 B=20 G1=38 G2=14 G3=17
	For Ø1.6						
	For Ø2.0						
	For Ø3.2						
	For Ø4.8						
	For Ø6.0	A=29 G2=17	G2=17	A=43 G2=17	A=58 G2=17	A=60 G2=17	
	For Ø6.4						
For Ø8.0	Not available	A=41 G2=21	A=44 G2=21	A=58 B=25 G2=21	A=62 B=25 G1=41 G2=21		
For Ø10							
For Ø12							
For Ø15							
For Ø16							
For Ø22	A=53 G2=26	A=55 G2=26	A=63 G2=26				
For Ø22							

Frame inside:
Type 2

Note: Dimensions being different from the dimensions shown in the upper column are shown in the lower column.

• **Metal connector**

		Code	Dimensions			
	For thermocouple	12P-2	ØA	ØB	ØD	E
		16P-2	7	12	18	38
	For resistance thermometer	12P-3	8.5	15.5	21.5	43
		16P-3	7	12	18	38

		Code	Dimensions			
	For thermocouple	12A-2	ØA	ØB	ØD	E
		16A-2	7	44.5	12.5	18
	For resistance thermometer	12A-3	8.5	50	16.5	21.5
		16A-3	7	44.5	12.5	18

		Code	Dimensions						
	For thermocouple	12A-2	ØA	ØB	ØC	ØD	E	G	ØD
		16A-2	15.5	12.5	23	19	16.5	3-Ø2.1	14
	For resistance thermometer	12A-3	19	16.5	32	25.5	19	3-Ø3.2	19
		16A-3	15.5	12.5	23	19	16.5	3-Ø2.1	14

CONNECTORS

CA connector

Technical drawings of the CA connector showing side views with dimensions: 25.4, 66.6, 12.7, 33.3, 14.5, 33.3, 43.3, 27, 13, 16, 15, 35, 26, 13.5, 2-Ø4. A mounting plate is also shown with dimensions 43.3, 27, 13, 16, 15. A panel cutout is detailed with dimensions 35, 26, 13.5, and 2-Ø4.

Pin materials

	(+) lead	(-) lead
For B, R, S	Copper	Copper alloy
For K	Chromel	Alumel
For E	Chromel	Constantan
For J	Iron	Constantan
For T	Copper	Constantan

SM connector

Technical drawings of the SM connector showing side views with dimensions: 17, 21, 10, 25.5, 2.2, 3, 8, 46.5.

Pin materials

	(+) lead	(-) lead
For B, R, S	Copper	Copper alloy
For K	Chromel	Alumel
For E	Chromel	Constantan
For J	Iron	Constantan
For T	Copper	Constantan

CONNECTION TIPS

The connection tips can roughly be divided into the tips for termination and the tips for extension wires. The tips for termination are used for terminating extension wires and are convenient for connections to terminals in a terminal board.

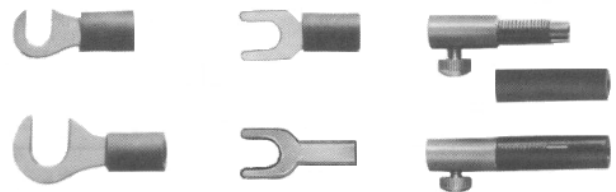

Classification	Terminals for connection				Terminals for relaying
Applications	For instrument terminals		For sensor terminals	For EB series recorder terminals	For connecting extension wires and thermocouple wires
Code	G	Y	U	F	B
Specifications					
Covering color	+: Red, -: White			+: Red, -: White	+: Red, -: Black

■ PROTECTIVE TUBE

● Metallic tube

Material	Code	Ordinary temp. °C	Maximum working temp. °C	Features
SUS304	CN	850	1000	18% chrome, 8% nickel copper, Good corrosion resistance and heat resistance
SUS316	32	850	1000	Effective in heat, acids and alkalis, Much better corrosive resistance than SUS304
SUS310S	42	1000	1150	Effective in heat
NCF600 (Inconel 600)	IN	1000	1150	Same heat resistance as SUS310S, Excellent corrosive resistance
SUS347	47	850	1000	Same corrosive resistance as SUS304
SUH446 (Sandvik P4)	P4	1000	1200	Strong resistance against heat, corrosion and sulfurous gas
Sandvik 253MA	MA	1000	1200	Good heat resistance and corrosion resistance
Hastelloy B	HB	800	1100	Suitable to hydrochloric acids in all kind of density and with temperature up to boiling point
Hastelloy C	HC	1000	1100	Good in ferric chloride, cupric chloride and wet chloride gas
Kanthal A-1	KA	1100	1350	Excellent mechanical strength at high temperature (Cr 24%, Co 1 to 2.5%, Al 5.5%, balanced with iron)
Titanium	TI	250	500	Better chemical corrosion resistance than SUS304
Cast iron	S5	700	800	Excellent mechanical strength, Used for melted aluminum
SUS316L	6L	850	1000	Intergranular corrosive resistance material
KTA-KU50	KU	1150	1200	Effective in heat and low-wearing
Teflon coating	TC	200	250	Teflon coating on SUS304, Strong resistance to chemicals on low temperature
Glass coating	GC	350	400	Glass coating in steel, Good chemical resistance

● Non-metallic tube

Material	Code	Ordinary temp. °C	Maximum working temp. °C	Features
Hard vinyl	VN	60	100	Suitable to corrosive fluids
Hard glass	GS	500	600	Effective in acids and alkalis, Susceptible to heat and mechanical impact
Quartz glass	QT	1000	1050	Small heat capacity, Quick response
High aluminum ceramic tube (JIS PT1, PS1)	NC	1400	1450	Excellent air-tightness, Strong resistance to molten metals and combustion gas
	AL	1500	1550	
Pure sintered aluminum (JIS PT, PS0)	DG	1700	1900	Strong resistance to neutral fire-proof materials, molten metals, glasses and lea-slugs
	SL			
Zirconia	ZR	1800	2100	Strong resistance to bases, acids, basic slugs and special molten metals
Silicone carbide	GK	1500	1700	Strong resistance to heat impact
Silicone nitrite	SN	1200	1600	Strong resistance to acids, oxide salts, heat impact and molten non-ferrous metals
Aluminum	HL	1600	1700	Strong resistance to acids and alkalis
Teflon tube	TF	200	250	Strong resistance to chemicals in lower temperature

■ ELEMENTS

Type	Code	Diameter (Ømm)	Ordinary temp. °C	Maximum working temp. °C	JIS class	Minimum diameter of protective tube (Ømm)			
						Metallic		Non-metallic	
						Single	Double	Single	Double
R	R05	0.5	1400	1600	2			6	8
B	B05	0.5	1500	1700	3			6	8
S	S05	0.5	1400	1600	2			6	8
K	K01	0.1			1* 2 3				
	K03	0.32				3.2	10	6	8
	K05	0.5							
	K06	0.65	650	850		4.8	10	8	13
	K10	1.0	750	950		10	12	10	15
	K16	1.6	850	1050		12	12	13	15
	K23	2.3	900	1100		22	22	17	21
T	T01	0.1	150	200	1* 2				
	T03	0.32	200	250		3.2	10	6	8
	T06	0.65	200	250		4.8	10	8	13
E	E03	0.32	400	450	1* 2 3	3.2	10	6	8
	E06	0.65	450	500		4.8	10	8	13
	E10	1.0	500	550		8	12	10	15
	E16	1.6	550	650		12	12	13	15
	E23	2.3	600	750		22	22	17	21
	E32	3.2	700	800		22	27	17	25
J	J06	0.65	400	500	1* 2	4.8	10	8	13
	J10	1.0	450	550		8	12	10	15
	J16	1.6	500	650		12	12	13	15
	J23	2.3	550	750		22	22	17	21
	J32	3.2	600	750		22	27	17	25
W95Re5-W74Re26	W05	0.5	2300						
*2 CR-AuFe	A02	0.2	Less than 300K	More than 4K					

The ordinary temperature is the temperature that a thermocouple can be used in air continuously.
 The maximum working temperature is the temperature that a thermocouple can be used in a short time for occasional uses.
 *1 "H" is added for Class 1 like as "HK06".
 *2 For CR-AuFe thermocouples, elements are covered by polyester.

● Double protective tube type

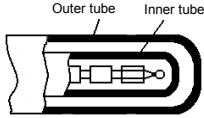
	Inner diameter (Ømm)	Inner diameter (Ømm)	
		Metallic	Non-metallic
	6	15	15
10	22	17	

REFERENCE TYPES OF EXTENSION WIRES

Type	Uses	Code	Composition (mm)		Outer sheath		Resistance (Ω/m)	Working temperature (°C)	Error allowance (μV)	Outer diameter (mm)
			+ lead	- lead	Material	Color				
R	Heat resistance	RXH	Copper 0.65 x 7pcs	Copper alloy 0.65x7pcs	Glass wool braided	Black	0.03	0 to 150	± 60	4x6.5
	Waterproof	RXV			Vinyl			0 to 90	± 30	5x8
	Thin type heat resistance	RXJ	Copper 0.3 x 7pcs	Copper alloy 0.3x7pcs	Glass wool braided		0.13	0 to 150	± 60	2.4x4
	Thin type general	RXI			Vinyl			0 to 90	± 30	3x4.9
K	Precision class heat resistance	KXHS	Chromel 0.65 x 7pcs	Alumel 0.65x7pcs	Glass wool braided	Blue	0.43	0 to 150	±100	4x6.5
	Precision class waterproof	KXVS			Vinyl			(-)20 to 90		5x8
	Thin type precision class heat resistance	KXJS	Chromel 0.32 x 7pcs	Alumel 0.32x7pcs	Glass wool braided		1.94	0 to 150		3x4.9
	Thin type precision class heat general	KXIS			Vinyl			(-)20 to 90		2.4x4
	Heat resistance	WXH	Iron 0.65 x 7pcs	Constantan 0.65x7pcs	Glass wool braided		0.38	0 to 150	± 60	4x6.5
	Thin type heat resistance	WXJ	Iron 0.3 x 7pcs	Constantan 0.3x7pcs	Glass wool braided			1.25		0 to 150
	Thin type general	VXI	Copper 0.3 x 7pcs	Constantan 0.3x7pcs	Vinyl		1.25	(-)20 to 90		3x4.9
	Waterproof	VXV	Copper 0.65 x 7pcs	Constantan 0.65x7pcs	Vinyl		0.22	0 to 90		2.8x4.5
	With sheath shield	WXA	Iron 0.3 x 7pcs	Constantan 0.3x7pcs	Stainless braided		1.25	0 to 150	± 60	2.8x4.5
	E	Heat resistance	EXH	Chromel 0.65 x 7pcs	Constantan 0.65x7pcs		Glass wool braided	Purple	0.51	0 to 150
Waterproof		EXV	Vinyl			(-)20 to 90	5x8			
Thin type heat resistance		EXJ	Chromel 0.3 x 7pcs	Constantan 0.3x7pcs	Glass wool braided	2.45	0 to 150		2.4x4	
Thin type general		EXI			Vinyl		(-)20 to 90		3x4.9	
With sheath shield		EXA			Stainless braided		0 to 150		2.8x4.5	
J	Heat resistance	JXH	Iron 0.65 x 7pcs	Constantan 0.65x7pcs	Glass wool braided	Yellow	0.38	0 to 150	±140	3.4x6.2
	Waterproof	JXV			Vinyl			(-)20 to 90		5x8
	Thin type heat resistance	JXJ	Iron 0.3 x 7pcs	Constantan 0.3x7pcs	Glass wool braided		1.25	0 to 150		2.4x4
	Thin type general	JXI			Vinyl			(-)20 to 90		3x4.9
	With sheath shield	JXA			Stainless braided			0 to 150		2.8x4.5
T	Waterproof	TXV	Copper 0.65 x 7pcs	Constantan 0.65x7pcs	Vinyl	Brown	0.22	(-)20 to 90	± 60	5x8
	Thin type heat resistance	TXJ	Copper 0.3 x 7pcs	Constantan 0.3x7pcs	Glass wool braided			0 to 150		2.4x4
	Thin type general	TXI			Vinyl		(-)20 to 90	3x4.9		
	With sheath shield	TXA	Stainless braided	0 to 150	2.8x4.5					
W	Heat resistance	NXH	Copper alloy 0.5 single	Copper alloy 0.5 single	Glass wool braided	White	3.10	(-)20 to 150	-	2x3
B	Heat resistance	BXH	Copper 0.65 x 7pcs	Copper 0.65 x 7pcs	Glass wool braided	Gray	0.014	0 to 150	-	3.4x6.2
	Waterproof	BXV			Vinyl			0 to 90		5x8
	Thin type heat resistance	BXJ	Copper 0.3 x 7pcs	Copper 0.3 x 7pcs	Glass wool braided		0.068	0 to 150		2.4x4
	Thin type general	BXI			Vinyl			0 to 90		3x4.9
S	Heat resistance	SXH	Copper 0.65 x 7pcs	Copper alloy 0.65 x 7pcs	Glass wool braided	Black	0.045	0 to 150	± 60	4x6.5

Specifications subject to change without notice. Printed in Japan (I) 2003. 7

CHINO CORPORATION
 32-8, KUMANO-CHO, ITABASHI-KU, TOKYO 173-8632
 PHONE: +81-3-3956-2171
 FAX: +81-3-3956-0915
 E-mail: inter@chino.co.jp
 Website: http://www.chino.co.jp/